

Change Your Clock Change Your Battery®:

Remind your loved ones to adopt an easy and life-saving habit

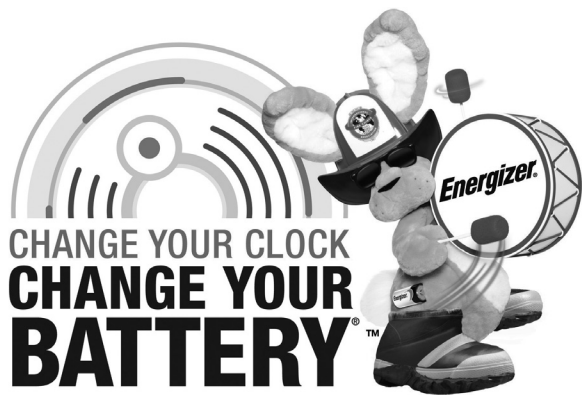

CHANGE YOUR CLOCK
**CHANGE YOUR
 BATTERY**™

By providing an early warning and critical extra seconds to escape, working smoke alarms cut the risk of dying in reported home fire structures in half. So when you set your clocks back on November 6, use the extra hour to make a life-saving change in your household—change and test the batteries in your smoke alarms and carbon monoxide detectors—and remind your friends, family and neighbors to do the same. This simple act takes just a moment, but is the best defense your family has

against the devastating effects of a home fire. This reminder to *Change Your Clock Change Your Battery*® comes from *Energizer*, your local fire department, and the International Association of Fire Chiefs.

"Change Your Clock Change Your Battery"™ program created by Energizer. Energizer, Energizer Bunny design, Change Your Clock Change Your Battery and other marks are trademarks of Energizer. ©2011 Energizer

*Claims substantiated by the National Fire Protection Association

Statement Stuffer for utilities, banks, cable companies to include with customer invoices.

Clip Art for Print Media



Change Your Clock Change Your Battery®:

Remind your loved ones to adopt an easy and life-saving habit

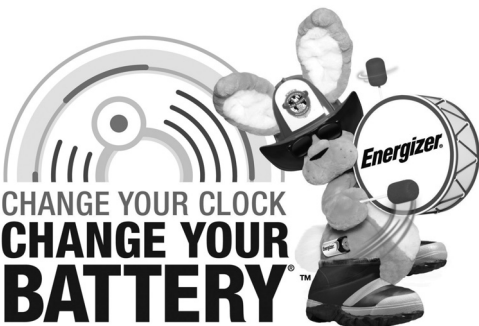

CHANGE YOUR CLOCK
**CHANGE YOUR
 BATTERY**™

By providing an early warning and critical extra seconds to escape, working smoke alarms cut the risk of dying in reported home fire structures in half. So when you set your clocks back on November 6, use the extra hour to make a life-saving change in your household—

change and test the batteries in your smoke alarms and carbon monoxide detectors—and remind your friends, family and neighbors to do the same. This simple act takes just a moment, but is the best defense your family has against the devastating effects of a home fire. This reminder to *Change Your Clock Change Your Battery*® comes from *Energizer*, your local fire department, and the International Association of Fire Chiefs.

"Change Your Clock Change Your Battery"™ program created by Energizer. Energizer, Energizer Bunny design, Change Your Clock Change Your Battery and other marks are trademarks of Energizer. ©2011 Energizer

*Claims substantiated by the National Fire Protection Association

Print Public Service Ad:
 size - 4-1/2 x 4-7/16
 OR,
 enlarge and use as flier or poster.

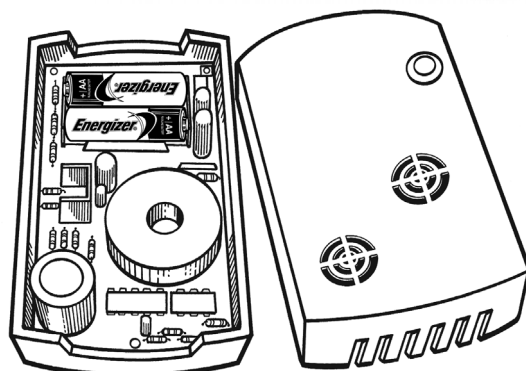
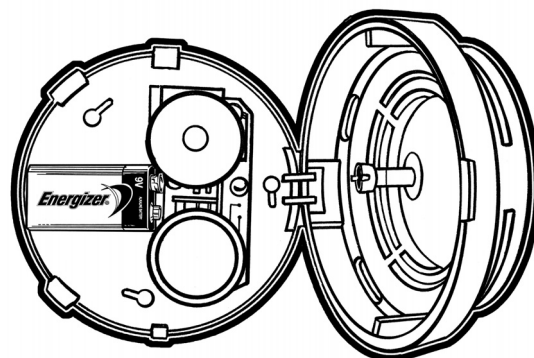

Campaign Logos

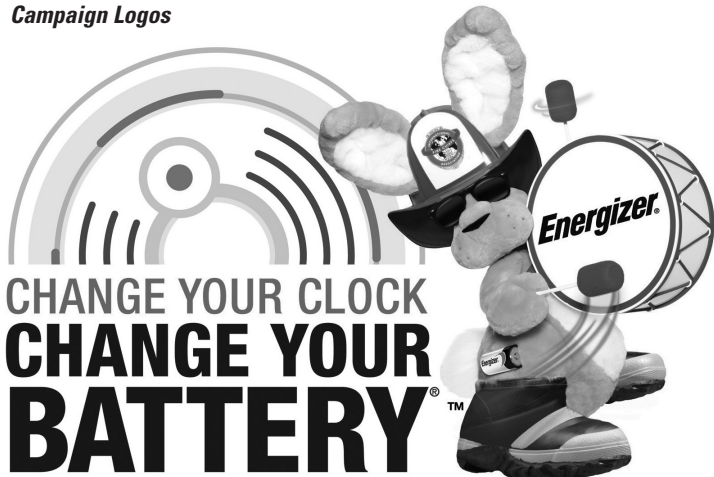

"Change Your Clock Change Your Battery"™ program created by Energizer. Energizer, Energizer Bunny design, Change Your Clock Change Your Battery and other marks are trademarks of Energizer. ©2011 Energizer